

NRSA Series

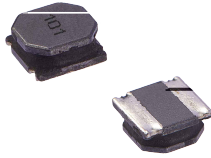

FEATURES

- Magnetic shield type wound inductor for power circuits using a ferrite magnetic material
- High magnetic shield construction and compatible with high-density mounting
- Larger current and lower Rdc were achieved by optimizing the ferrite core figure.
- Operating temperature: -55 to +125°C (including self-temperature rise)
- AEC-Q200 qualified
- Quantity: 3000pcs

APPLICATION

- Smart cockpit

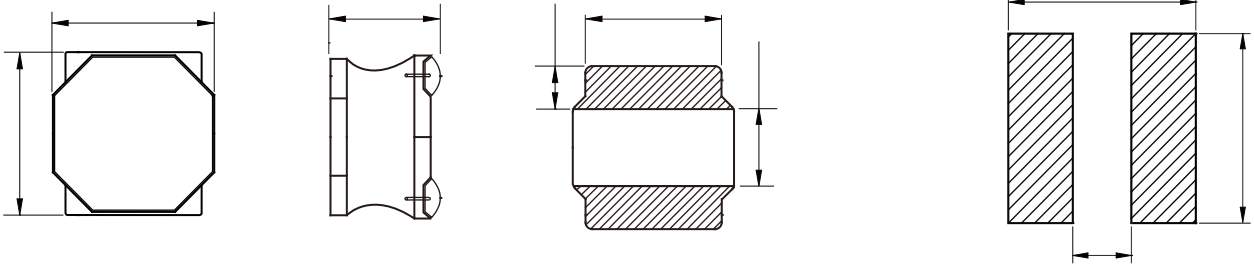

	(μH)		(A)	Saturation (A)	(Ω)
NRSA4018W-101M	100	$\pm 20\%$	0.42	0.46	1.9

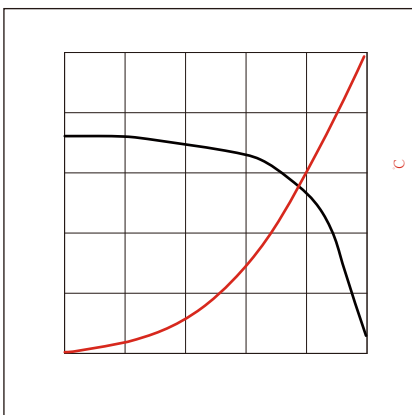

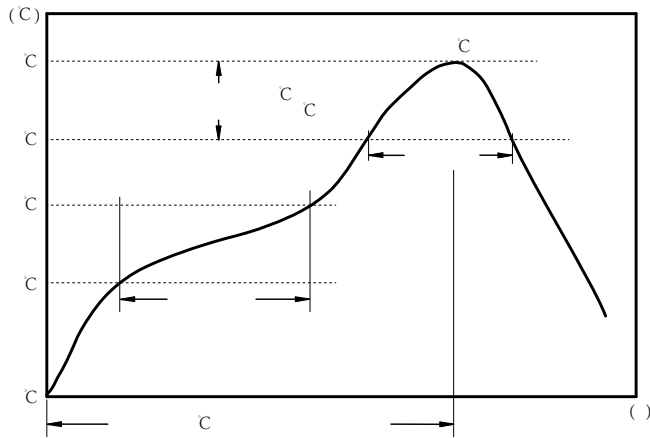

C
C
C

:

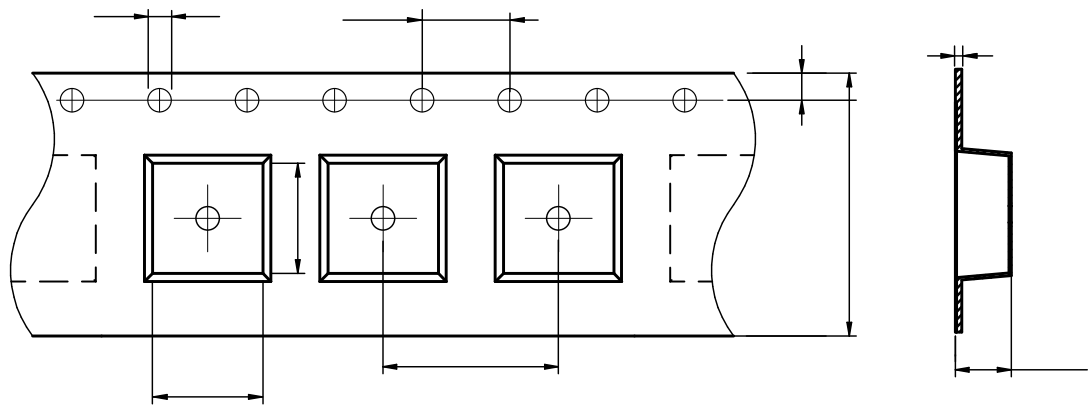

NRSA4018W	4.3 ± 0.1	4.3 ± 0.1	1.5 ± 0.1	4.0 ± 0.1	8.0 ± 0.1	12.0 ± 0.3	2.25 ± 0.1	1.75 ± 0.1	0.30 ± 0.05

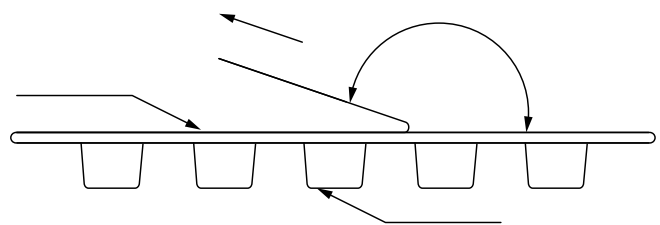

The peel force of top cover tape shall be between 0.3 to 1.17 N

Marking	101
---------	-----

:

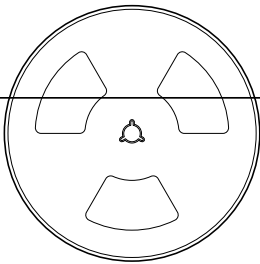
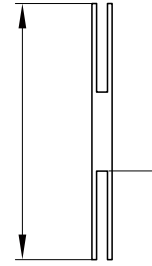
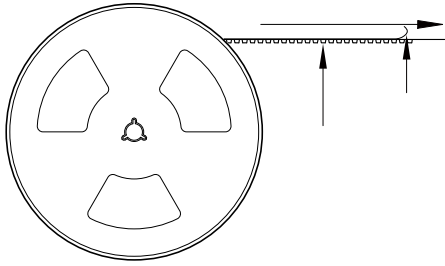

3000 Pcs/Reel

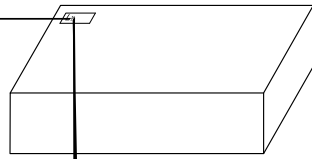

3 Reel /Inner box(9K Pcs)

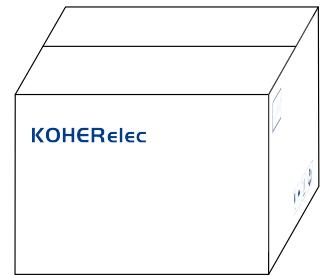

3 Inner box/Carton box(27K Pcs)

:

-
-
-
-
-
-
-
-
-